

PROTECTION

Let us protect your water heater, washing machine, dishwasher, coffee-maker... soft water defends your water circuits against scale deposits, thus keeping your whole heating installation and all your appliances efficient and clean. Your pipes and heating system will constantly supply you with a comfortable, safe heat. Your showerhead and taps will continuously provide you and your family with a generous stream of water...

SAVINGS

Spend your energy and time on recreation and relaxation, not on scouring your bathtub or sanitary ware! Save your money for family trips or hobbies, not for excessive amounts of washing powders and cleansing products, maintenance visits from your plumber, repair costs for your household appliances...

RELIABILITY

The EcoWater softeners ensure you constant satisfaction, thanks to their well-proven reliability and their legendary toughness! They are well built, durable, simple to install, cheap to run and easy to maintain.

Tap into our Expertise!

1925 ~ Lynn Lindsay obtains his first patent for a water conditioner automatic control valve and establishes the Lindsay company. ~ **1981** ~The Lindsay company becomes a member of the Marmon Group of Companies and buys two years later the Water Refining group and its 2 well-known brands: Miracle Water & Servisoft. ~ **1988** ~Merger of the different water treatment brands and creation of the ECOWATER SYSTEMS group. ~ **1992** ~ EcoWater Systems produces annually over 220 000 domestic water conditioners and becomes the world's largest producer in this specialty. The group is represented by over 2 000 qualified dealers worldwide. ~ **2001** ~With the launch of a new range of domestic softeners with high-tech innovation features, EcoWater Systems strengthens its international leading position. ~ **1999-2004** ~ Acquisition of EcoWater Systems Europe's affiliates (Watrex - Belgium, Epuro SAS - France, EcoWater Systems Deutsche Lindsay Wassertechnik - Germany, Epuro Polska - Poland). ~ **2005** ~ Foundation of Ecowater Systems Romania.

Ever since EcoWater Systems was launched in 1925, we had a clear vision: **PROVIDE YOU WITH WATER THAT'S CLEARER AND CLEANER THAN YOU'VE EVER EXPERIENCED.** And because we design and manufacture 95% of our products and components ourselves, we can guarantee you top quality softeners! That's why our expertise has been recognised by many independent agencies in the U.S., as in Europe and why our softeners or their components carry one or more of the shown quality seals.

Like millions of satisfied customers, you too can tap into our long expertise. Our qualified dealers are an additional assurance that you have made the right choice.

**SO LET US TAKE CARE OF YOUR WATER PROBLEM,
AT HOME OR WHERE YOU WORK... TODAY!**

Your authorised dealer:



ECOWATER
SYSTEMS®



www.ecowater-europe.com



We are ISO9001 certified. The manufacturing facility where the EcoWater units are produced is ISO9001 certified.

ISO9001 is the most stringent of the three quality standards issued by the International Standards Organisation.

ISO registration ensures a quality system from initial specification and product design through delivery to the customer. It demonstrates commitment to product quality and customer satisfaction.



Technical specifications may be altered without warning. EcoWater Systems, Lindsay, Dot-Matrix Digital Demand, Multi-Wrap and Ease are all registered trademarks.

This document cannot be reproduced in full or in part without prior written authorisation.

Responsible publisher:
EWSE - Geelseweg 56,
B-2250 Olen.

EN-2006/01-30364



ECOWATER
SYSTEMS®



ENJOY THE BENEFITS OF SOFT WATER!

BEAUTY

Take a bath or shower with soft water and you will feel the difference: the water will smoothen your skin and relax you as never before! Enjoy a shave without irritation and radiate with your manageable, shiny hair... Soft water will bring out the best in you.

COMFORT

Wrap your children in the softest bath towels. Feel how smooth your family's clothes come out of the washing machine, clean right to the heart of the fibre. See how they preserve their colours so much longer. Get more satisfaction and longer pleasure from your clothes and grant your household appliances a far longer life... thanks to soft water.

ECOLOGY

With soft water, your bubble bath will foam, your shampoo, washing powder and cleansing agents will clean... unbelievably fast and easy. Enjoy natural soap and use phosphate-free washing powders thanks to nature's best friend... soft water.

One EcoWater Softener for all

The EcoWater softeners meet the needs of ALL users, either professional or private. They are elegantly designed to incorporate the most recent technical innovations in the field of water conditioning and monitoring.

EcoWater softeners feature the most advanced technology:

- * **Bypass valve:** (not shown) can temporarily halt the water flow through the softener without the need to disconnect the unit.
- * **Control valve:** (not shown)
 - has five/six cycles;
 - is made of a corrosion-proof plastic alloy;
 - has few moving parts and quick disconnect snaps, allowing easy maintenance.
- * **Patented Dot-Matrix Digital Demand unit:**
 - ensures an automatic regeneration of the softener according to parameters stored in the microprocessor memory; these parameters take into account your actual water pattern and your water's hardness;
 - saves considerably on regenerating salt, thanks to our efficient regeneration process;
 - 24V AC powered for maximum operational safety.
- * **Large diameter (1") distributor tube:** enables higher flow rates, guaranteeing optimum soft water production whenever required.
- * **Multi-Wrap™ resin tank:**
 - its strength is ensured by an external glass fibre filament winding;
 - NO risk of rust or corrosion;
 - "Food-grade" certified by the "Underwriters laboratories" inspection agency.
- * **Resin bed:**
 - pre-determined quantity of resin (polymeric beads that soften the water through ion exchange);
 - "Food-grade" certified by the US Public Health inspection agencies.
- * **Self-cleaning distributors:** allow high flow rates and are automatically cleaned by the pressure of the water flow during the backwash cycle.
- * **Active brine valve:**
 - its great simplicity and precision of operation avoid the need to use solvents, which would risk to contaminate the water;
 - shuts off automatically if needed to avoid spillage from the salt tank.
- * **Salt tank:** holds a generous quantity of salt, avoiding e.g., weekly refills.

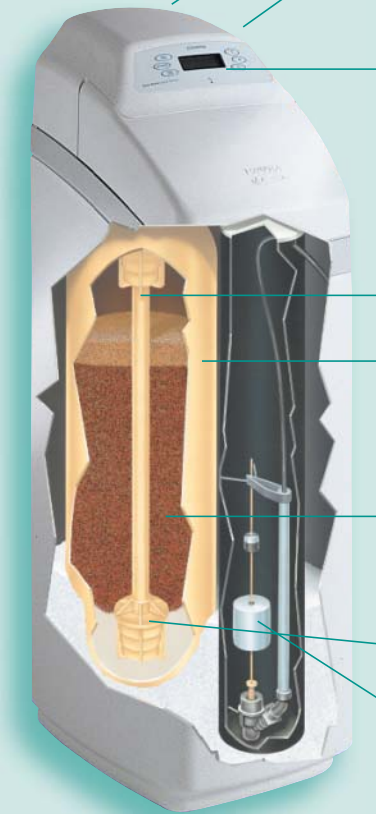

MODEL	ESM 11	ESM 15	ESM 18	ESM 25	ESM 42
Capacities/salt dose (*Fm ³ /kg)	30/0.4 49/0.9 65/1.6	48/0.7 80/1.4 113/3.8	56/0.8 94/1.6 133/4.1	76/1.2 128/2.4 172/4.4	113/1.5 193/3.0 262/5.6
Resin quantity (litres)	10.5	14.7	17.3	24.6	42.4
Service flow/min	15	23	30	36	34
Max. clear water iron (PPM)	0	4	5	8	11
Capacity salt tank (kg)	27	41	91	91	113
Dimensions (cm)	A: 54 B: 41.4 C: 66.8 D: 43.2 E: 32.4 F: 8,6	A: 70 B: 58.4 C: 83.8 D: 43.2 E: 32.4 F: 8,6	A: 50 B: 35.5 C: 115.5 D: 96.5 E: 83 F: 8,6	A: 50 B: 35.5 C: 115.5 D: 96.5 E: 83 F: 8,6	A: 35.5 B: 35.5 A1: 40.5 B1: 40.5 C: 143.8 C1: 93 C2: 81 D: 126 F: 9,5
Min. flow rate for a regeneration (l/min)	11				
Operating water pressure limits (Bar)	1.4 to 8.6				
Operating water temp. limit (°C)	2-49 °C				
Electrical rating	Transformer 240 VAC to 24 V AC				

These data are WQA certified.

EASE-y...

Performing an operational evaluation of your EcoWater softener, is as easy as picking up your phone with our EXCLUSIVE EASE* feature! Just transmit the service data, efficiency and other functions over the phone for instant review by an EASE technician.

... as 1, 2, 3

Monitor your EcoWater softener from anywhere in your home, 24/7, with our patented remote monitor and its wireless digital electronics:

1. Green = go (everything OK)
2. Yellow = caution (low on salt)
3. Red = stop! (call your authorized EcoWater dealer).

EcoWater's little Giants – ESM 11 & 15

To all flat-dwellers and people with limited space in their home, we proudly present our compact ESM 11 and 15 softeners. Installed under your kitchen sink or close to your household appliances, in your bathroom or in the laundry room, these little giants guarantee you a year-round soft water supply.

These two softeners are the perfect answer to the needs of most households and families with limited space.

EcoWater's discrete ESM 18, 25 & 42

The family-sized ESM 18 and 25 softeners with their elegant design ensure you total discretion. Installed in your laundry room, garage or cellar, they have sufficient capacity to cover virtually all household water needs.

Our two-tank ESM 42 model is the ideal softener for households with bigger than normal water needs, as well as for bakeries, hair dresser's, beauty parlours...

The large capacity of their salt tanks (90 to 113kg) allows them longer independent working abilities.

These ESM softeners are ideally suited for larger families and small businesses. Similarly, they can fulfil the needs of independent producers and small industries that use large volumes of water in their production process.

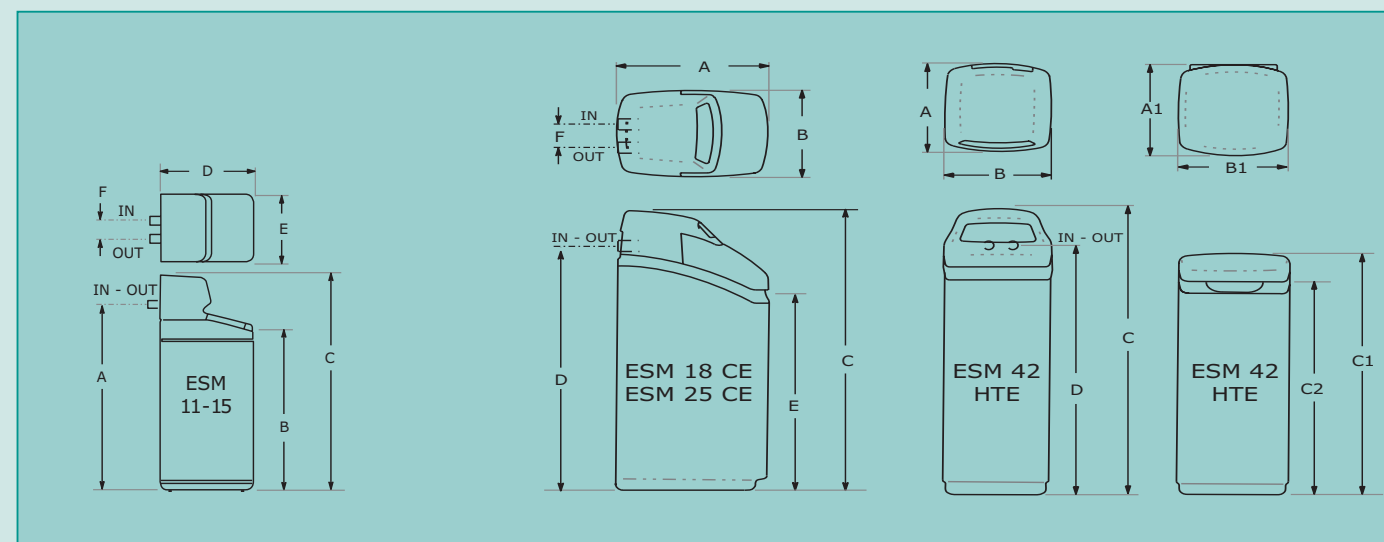

www.ecowater-europe.com